

RoHS

Version No.	Modification	Date
A		

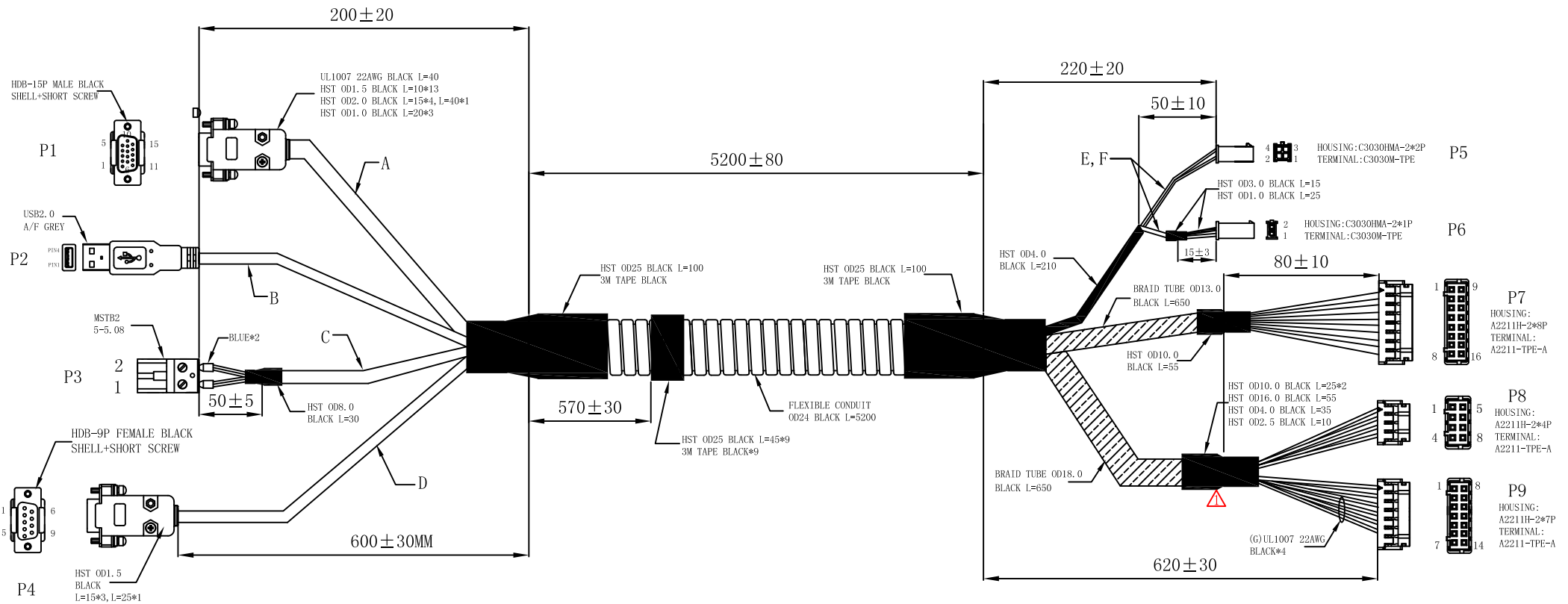

WIRE:

- A: (TS7*0.12*1.5 (FM-PE)*1C+SP (TS45*0.1)*2.3 (PVC)*1C)*3+TS7*0.12*0.85 (PVC)*1P+AL+D(7*0.16)+B(TS192*0.1) OD7.5 GREY PVC
- B: TS7*0.127*0.85 (HD-PE)*1P+TS7*0.2*1.1 (PVC)*2C+AL+D(TS7*0.12)+B(TS80*0.12) OD4.8 GREY PVC
- C: TS7*0.32*1.5 (PVC)*8C+F OD6.9 GREY PVC
- D: TS7*0.25*1.3 (PVC)*3C+MY+B(TS96*0.12) OD5.1 GREY PVC
- E: UL1533 24AWG (AS7*0.2*1.1*1C+SP (TS35*0.1) OD2.2 PVC BLACK
- F: UL2468 24AWG*2F (TS11*0.16) 1.5*3.0 PVC (BLACK BLACK/WHITE)
- G: UL1007 22AWG (TS17*0.16*1.6) BLACK

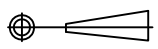

Ecocables Electronics Co.,Ltd
www.ecocables.net

Customer			Customer No.		
Material name			Approved	Tim. Z	
Unit	Scale	Free	Checked	Daivd.L	Revision date
mm			Drawn by	Percy.F	Sep 19, 2017
				Drawn date	Jul 31, 2017